

# GRDR-1

## Series single tank softening valve Installation, use and maintenance manual

(GRDR2-1, GRDR4-1, GRDR10-1, GRDR10-1S)



Scan Qr cord for the latest

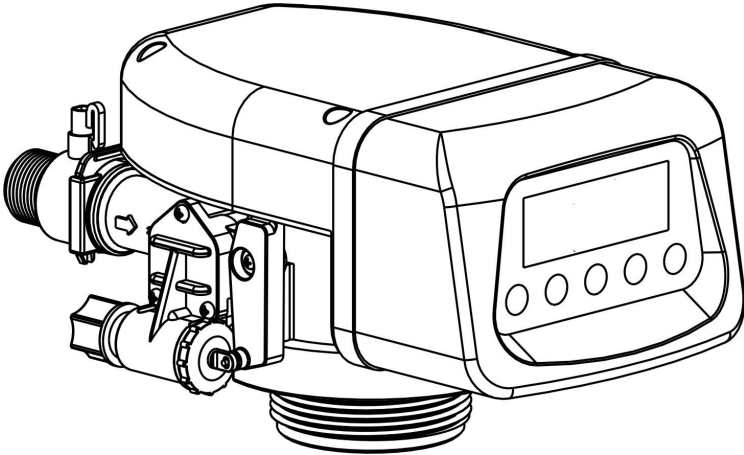

GRDR-1 shift

animation



GRDR-1 install

animation



DR10-1S install

animation



GR10-1S install

animation



# I . Operating Board

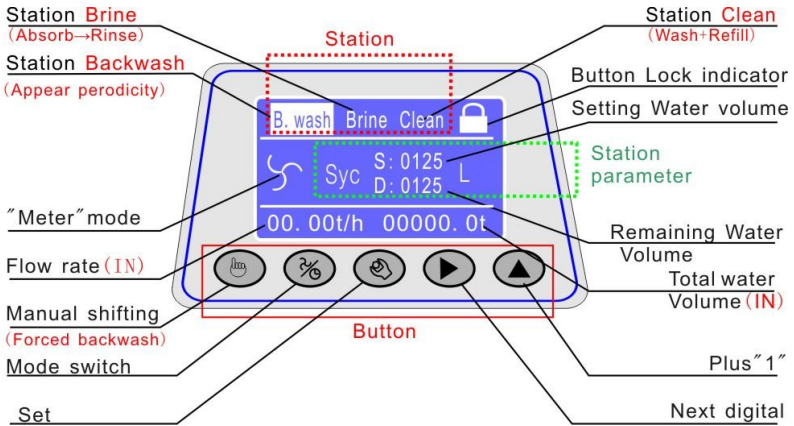

## 1、Instructions of the LCD display controller







**Pic1: LCD Screen**

### Flow mode" S "interface





	<p><b>B.wash:</b>(Appear according to the setting cycle value)</p> <p><b>S:0125:</b> Setting water for backwash , measured by the inlet flow meter,</p> <p><b>D:0125:</b>Decrementing State, Decrement to zero and switch to the next station ;</p> <p><b>00.00t/h:</b> The current flow rate of inlet</p> <p><b>0000000t:</b> Accumulative water amount of inlet</p>
	<p><b>Brine(Brine in → Slow wash)</b></p> <p><b>S:0125:</b> Setting water for Brine absorb and Slow wash, measured by the inlet flow meter, it is amount of water passing through the ejector</p> <p><b>D:0125:</b>Decrementing State, Decrement to zero and switch to the next station ;</p>



	<p><b>Clean (Wash+ Refill)</b></p> <p><b>S:0100:</b> Setting of Washing and refill to salt tank water, measured by the inlet flow meter;</p> <p><b>D:0100:</b> Decrementing State,Decrement to zero and switch to the next station;</p>
	<p><b>Soft (Softening)</b></p> <p><b>S:0005.5:</b> water volume of one cycle setting, measured by the inlet flow meter.unit:ton</p> <p><b>D:0005.5:</b> Decrementing State, to zero and switch to the next station</p>

**Time mode “” interface**



 <p><b>B.wash</b>(Appear according cycle)</p>	 <p><b>Brine</b>(Brine→Rinse)</p>
 <p><b>Clean</b>(Wash+ Refill)</p>	 <p><b>Soft</b>(Softening)</p>



**The operation button:**

: Manual button; : Parameter setting; : Mode Switch; : next; : plus 1

**A、Unlock :** Press and hold  &  simultaneously for one second ,Displaying .

**B、 Lock :** After three minutes of inactivity, the display panel will automatically lock.

**C、  Mode switch:** When unlocked, pressing it switches between time mode  and meter mode .

- D、 **Manual** button: When unlocked, pressing it switches to the next station.
- E、 **Parameter setting**: When unlocked, pressing it display the interface to change parameter settings.
- F、 **Backwash**: When locked, press 6 times the valve shift to **B.wash** station.

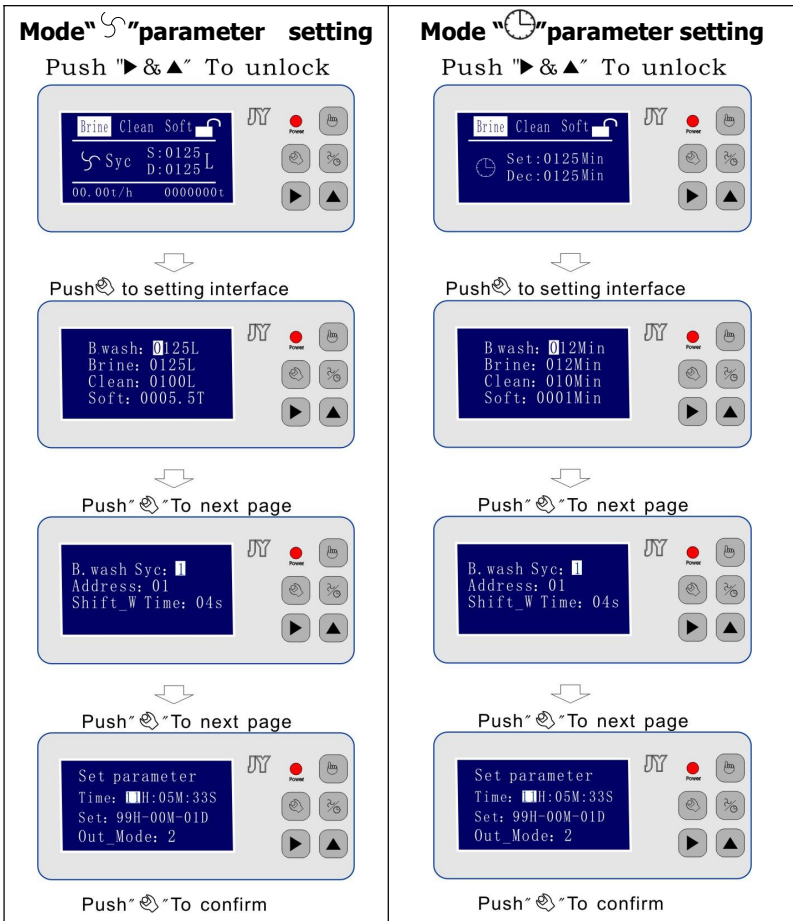

## 2、 LED Controller Operation instruction

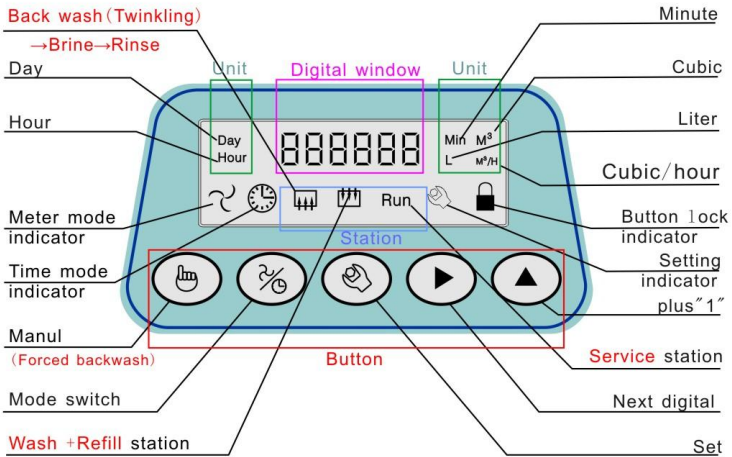

**Pic2: LED Screen**

### LED Display

Day \ hour \ min \ M<sup>3</sup> \ L \ M<sup>3</sup>/H are the units of time or flow, respectively, with the content, as suggested by the highlighted display

🌀: Flow mode symbol

🕒: Time mode symbol

📊: Indicator of station **Brine**→**Slow wash** station

**Twinkling when the valve is in B.wash station**

📊: Indicator of **Wash + Refill** station

**Run:** Indicator of **Softening** station

👉: Enter to the setting status indicator

🔒: Buttons locked indicator

**Button:**

**Name:**

👉:

**Manual button:**Unlock state.press it the valve shifting to next station

**Backwash:** Lock state.press it 6 times the valve shifting to **B.wash**

## station

: Parameter Set

: Mode switch

: Next

: Plus 1

**Setting the defined parameters**

**C1:** Meter Mode, Setting water for Brine inhalation and slow wash water.

Unit: L

**C2:** Meter Mode, Setting water of **Wash+Refill**. Unit: L

**C3:** Meter Mode, Setting Softening water quantity of one cycle. Unit: m<sup>3</sup>

**CO:** Meter mode: setting water volume for B.wash(backwash).unit:L

**C4:** Time mode: Setting Brine in and slow wash time. Unit: Min

**C5:** Time mode: Setting **Wash + Refill** water time. Unit: Min

**C6:** Time mode: Setting Softening time of one cycle. Unit: Min

**CP:** Time mode: setting time for B.wash.unit:Min



**C7:** Hour clock setting 0-23(Hours )



**C8** Minute clock setting 0-59(Minutes )

**C9** Delay Regeneration 0-23. if the valve is in servicing and can not switch to regenerate.it can be take delay regeneration.set a day any 0-23 hour , set 99 is to cancel this function.

**CF:** When the delay regenerate is enabled, If you want to take days as the unit of time; Regenerate once per set number of days. To achieve daily regeneration, set parameter C6 not more than one day (1440 minutes)

**CC:** Relay output control mode , set the mode 0, 1, 2, 3, 4, 5, 6 in the following table(page:9).

**CL:** Number of regeneration: Such as setting "2", the program will realize  and  twice one cycle ;

**CE:** Backwash cycle: The number is set to indicate how many cycles()  
→→**RUN**)backwash is performed once;

**(1)、Working station parameter**

	<p>🌀: Meter mode</p> <p>🏠: Station(Wash+Refill)</p> <p><b>C2-060:</b> Station water volume is set as 60L. Alternately display the decrement state, decrement to zero and switch to the next station.</p>

**(2)、Parameter setting (Flow mode example)**

	<p>Simultaneously press the ▶ &amp; ▲ buttons to unlock</p> <p>Press 🌀 to enter parameter setting interface</p> <p>Press ▲, plus 1 to change value of the number.</p> <p>Press ▶ to confirm ,press it continue proceed to next C2、C3、CO.Nether to Set C4→CP to</p> <p>Press 🌀 to time mode.</p>
--	---

**(3)、Instantaneous flow and accumulative water quantity query**

	<p>locked state 🗝️</p> <p>Press ▶ to display the current flow rate of inlet .unit is M<sup>3</sup>/h</p>
	<p>locked state 🗝️</p> <p>Press ▲ to display the accumulated water inlet, unit is M<sup>3</sup></p>

**II、Input/output control instructions**

### 1、 Interlock line connection as below

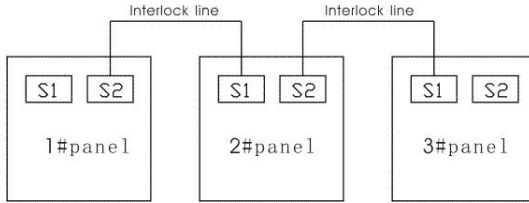

**Pic3: Interlock**

### 2. External control interface

In RUN station, The valve can be controlled into **Brine** (with a valve symbol) by the external other control system.

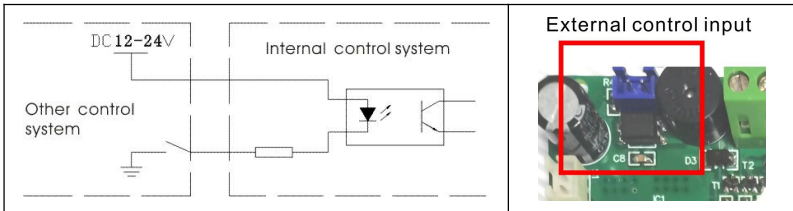

**Pic4: External control input**

### 3. Relay Output and mode set (CC)

A. The contact capacity of the relay is 5A/250V.





B. Relay output port:

**NO**= normally open, **NC**=normally closed, **COM** = common

C. When connecting the output of the relay, the AC110V-220V power supply input end shall be connected with the leakage circuit breaker.

**In different modes, the relay outputs NO and COM, which is connected as "C", disconnected as "×"**

Mode	 B.wash	Brine→ Rinse	 Clean Wash+Refill	<b>RUN</b> Soft	Valve shifting
0	<b>C</b>	<b>C</b>	<b>C</b>	<b>C</b>	<b>×</b>
1	<b>C</b>	<b>C</b>	<b>C</b>	<b>×</b>	<b>×</b>
2	<b>×</b>	<b>×</b>	<b>×</b>	<b>C</b>	<b>×</b>
3	<b>C</b>	<b>C</b>	<b>C</b>	<b>×</b>	<b>×</b>
4	<b>C</b>	<b>C</b>	<b>C</b>	<b>×</b>	<b>×</b>
5	<b>×</b>	<b>×</b>	<b>×</b>	<b>CX</b>	<b>×</b>
6	<b>C</b>	<b>×</b>	<b>×</b>	<b>×</b>	<b>×</b>

Mode	Applications
0	<b>Inlet Solenoid valve mode:</b> Pressure relief during transposition, lever switch and feed pump control. Pic 5
1	<b>Inlet pump mode:</b> When its station is in  (B.wash、Brine、Rinse) and  (Clean+Refill), Start the inlet booster pump
2	<b>Outlet pump mode:</b> For example, for subsequent RO high pressure pump start-stop control.
3	<b>Tow valve one RUN &amp; one standby water inlet solenoid valve mode:</b> Interlock line connected. When one valve completes  (B.wash、Brine、Rinse) and  (Clean+Refill) and switches to <b>soft(Run)</b> station, judge that if another valve is also in <b>Run(Soft)</b> station, the valve close its own inlet solenoid valve and wait for backup. As shown in figure 6.
4	<b>Inlet solenoid valve double valve parallel interlock respectively backwash mode:</b> Interlock line connection is required, this mode for filter valve use.
5	<b>CX(Mode2 additional conditions) :</b> When the inlet flow meter check the water flow signal in <b>Soft</b> station.the Relay is Connected.
6	<b>Backwash booster and compressed air mode</b>

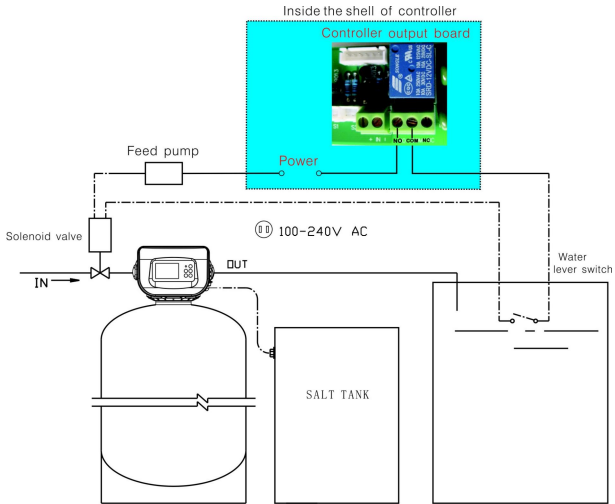

**Pic5: Mode(0): Solenoid valve liquid level switch and feed pump**

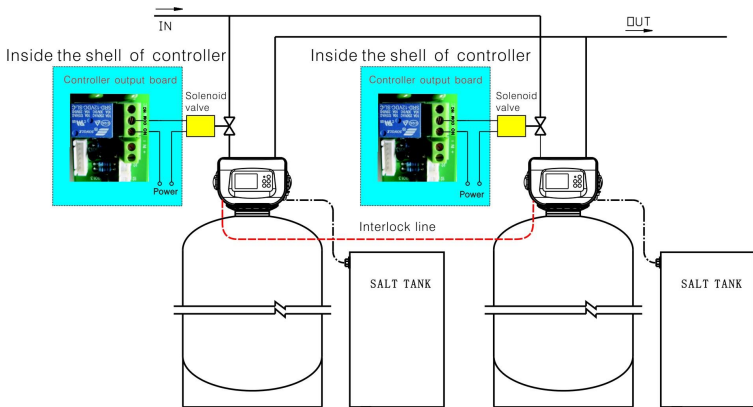

**Pic6: Mode(3): Tow valve one RUN & one standby inlet water solenoid valve mode:**

### III、Process

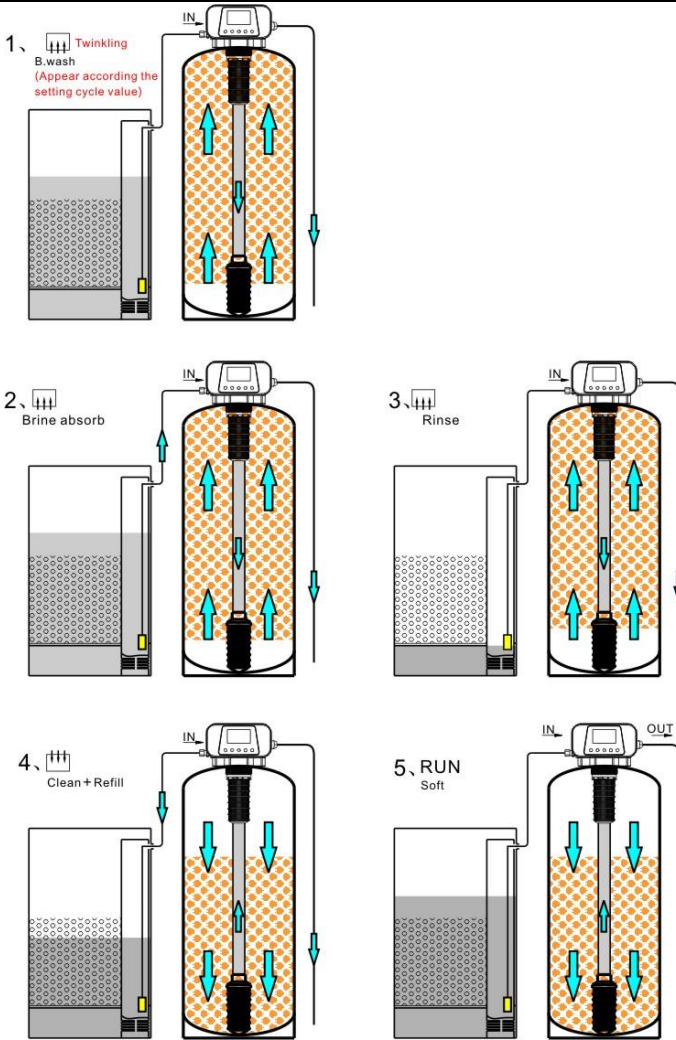

Pic7: GR-1 fixed bed back flow regenerate flow process

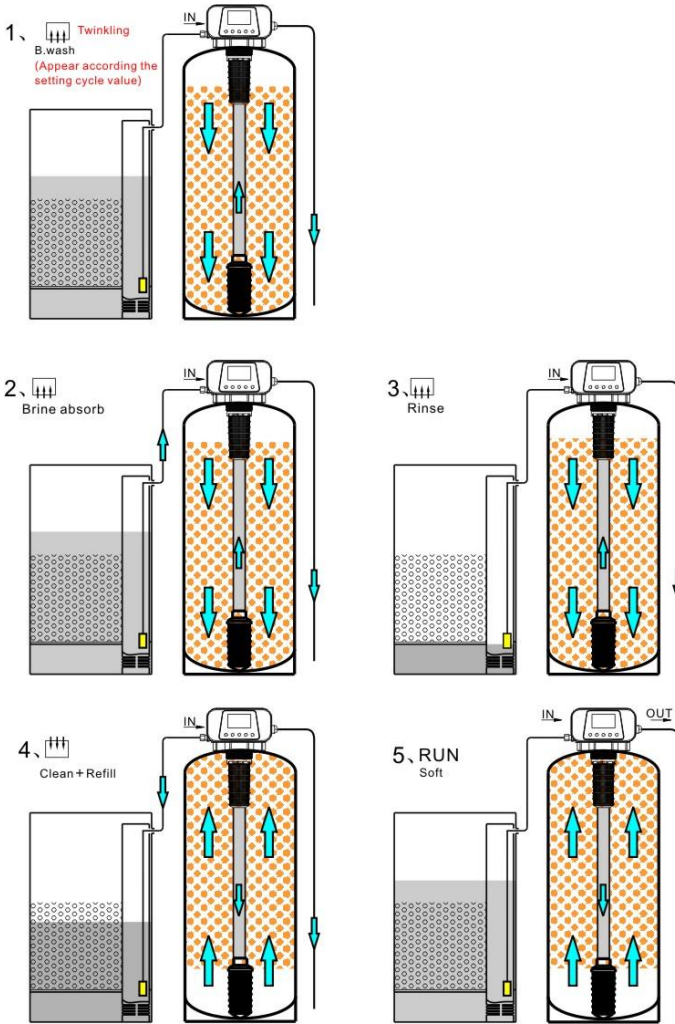

Pic8: DR-1 floated bed process

## **IV Configuration, installation and raw water condition**

- 1. If the raw water contains mechanical impurities of gel or powder, it is necessary to install sand filter, cloth bag or disc type functional filter, factory valve inlet filter can only ensure the occasional large particles into the valve body.*
- 2. The diameter of the exchange tank should meet the flow rate requirements of ion exchange.*
- 3. The volume of the salt tank is not less than the volume of the exchange tank.*
- 4. The GR fixed bed resin filling rate ensures 30% backwash space on the top of the exchange tank.*
- 5. The DR floated bed resin filling rate 90% space of the tank. to avoid resin layer disorder.*
- 6. Drainage pipe exports nearly flush with the ground, too high or too low will affect the equipment of Brine, Pipe must be mounted stable.*
- 7. Pipe valve specifications is not less than control valve in and out of the size.*
- 8. Water static pressure is 0.1~ 0.6 MPa. water temperature is 0°C~55°C .*
- 9. the equipment is installed in the room, the humidity should not be too high, there should be no corrosive chemical gas around, to avoid strong electromagnetic interference to affect the power supply of the control valve.*
- 10. Floor drain or trench drainage shall be set around the equipment to avoid accidental water leakage causing the floor and other indoor items to be flooded.*

**GR2-1\DR2-1 dimension drawing**

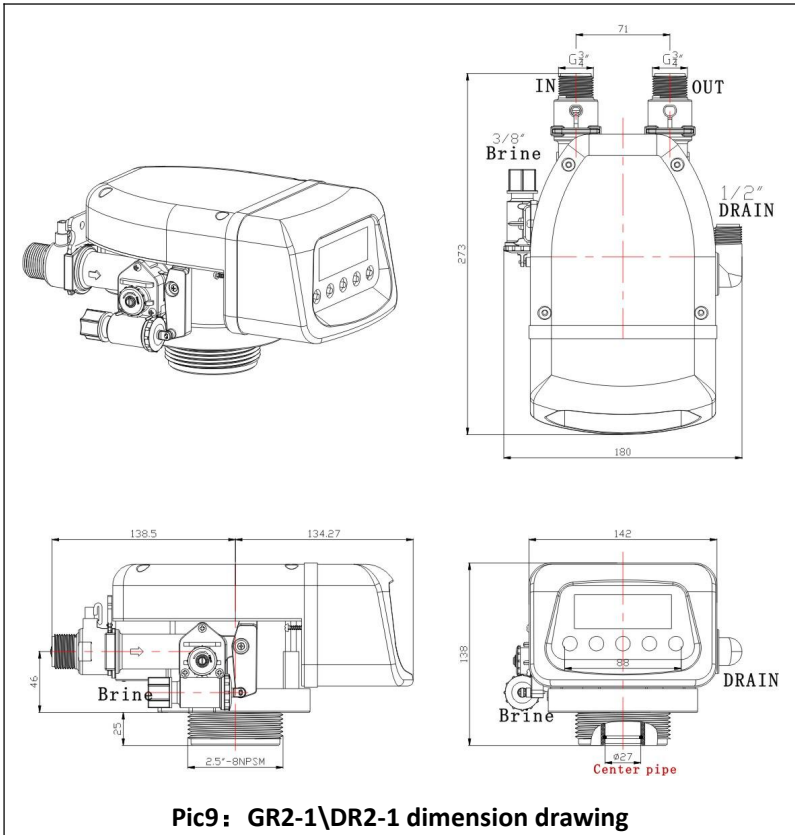

**Pic9: GR2-1\DR2-1 dimension drawing**

**GR4-1\DR4-1 dimension drawing**

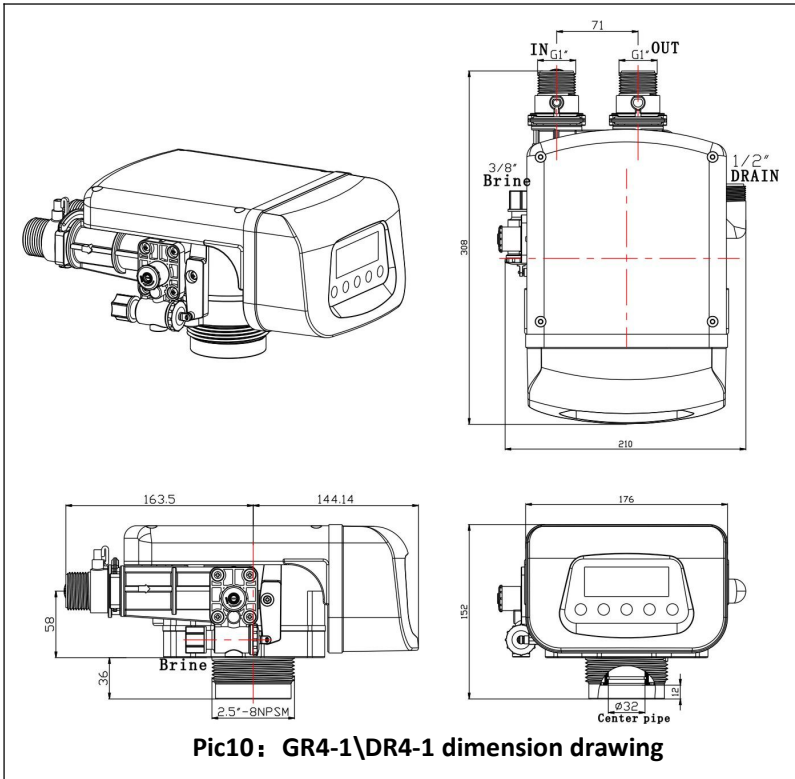

**GR10-1\DR10-1 dimension drawing**

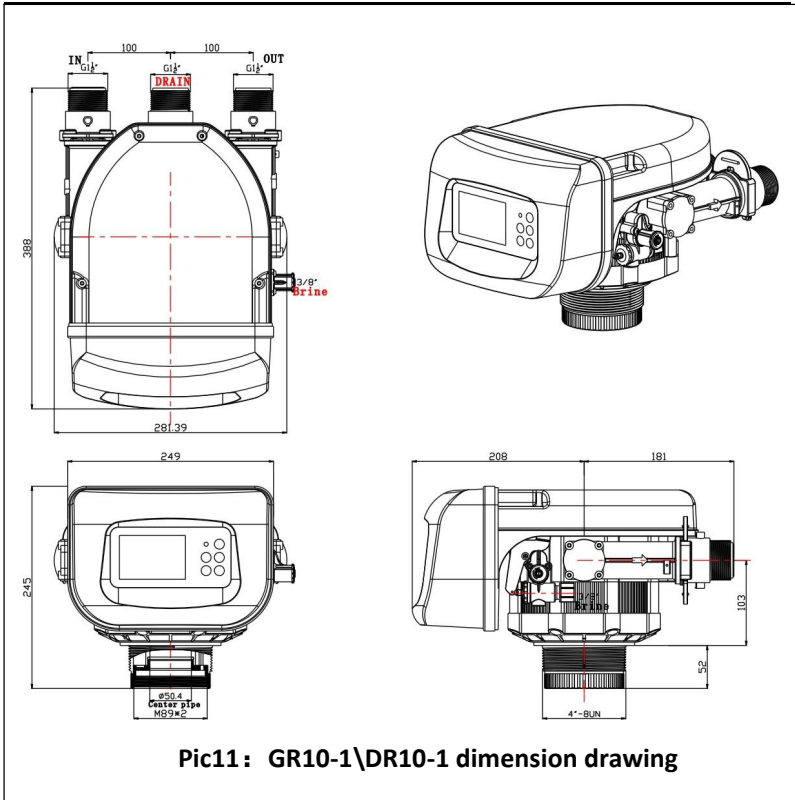

**Pic11: GR10-1\DR10-1 dimension drawing**

**GR10-1S\DR10-1S dimension drawing**

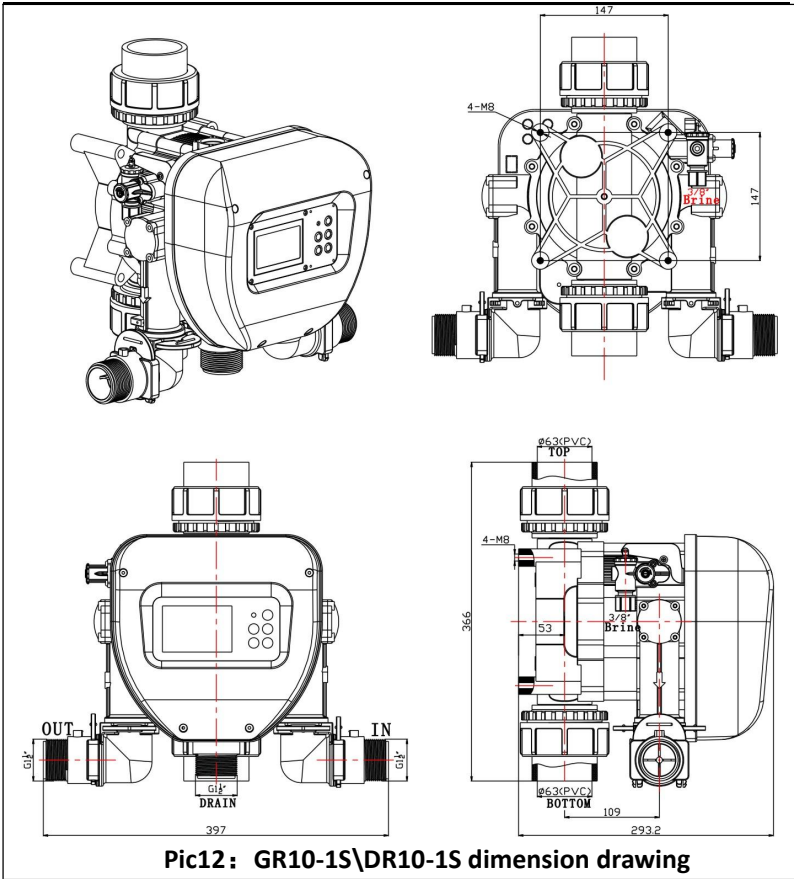

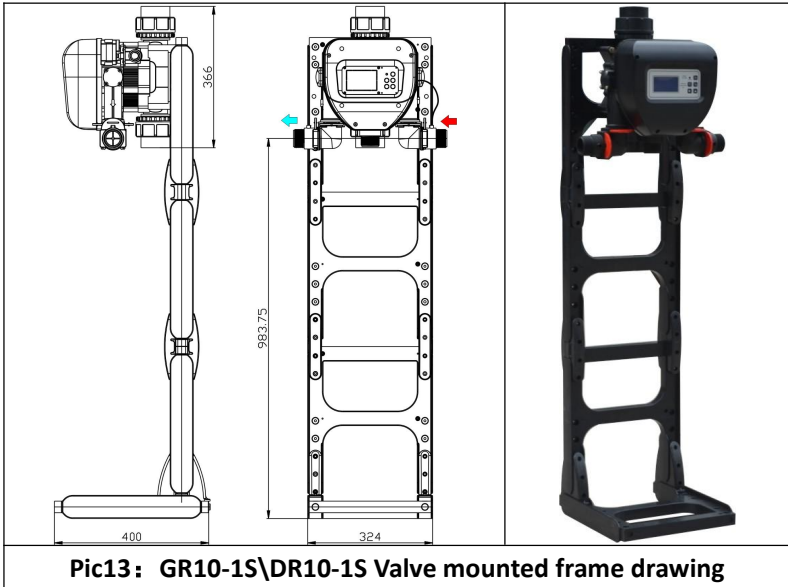

**Pic12: GR10-15\DR10-15 dimension drawing**

## GR10-1S\DR10-1S Valve mounted frame drawing





## V. Configuration and setting

## Formula for GR

Describe	Display	Formula
Service	<b>RUN (Soft) : T</b>	$C3 = [\text{resin filling volume (L)} \times 90\%] \div \text{Raw water hardness (mmol/L)}$
Brine absorb →Rinse	 <b>(Brine) : L</b>	$C1 = \text{Resin filling volume (L)} \times 250\%*$
Wash+Refill	 <b>(Clean) : L</b>	$C2 = \text{Resin filling volume (L)} \times 200\% (40\% + 160)**$
Backwash	 <b>(B.Wash) : L</b>	$C0 = \text{Resin filling volume (L)} \times 100\%$

**Formula for DR**

describe	display	Formula
Service	<b>RUN (Soft) : Ton</b>	$C3 = [\text{resin filling volume (L)} \times 70\%] \div \text{Raw water hardness (mmol/L)}$
Brine absorb →Rinse	 <b>(Brine) : L</b>	$C1 = \text{Resin filling volume (L)} \times 150\%^*$
Wash + Refill	 <b>(Clean) : L</b>	$C2 = \text{Resin filling volume (L)} \times 150\%^{**}$
Backwash	 <b>(B.Wash) : L</b>	$CO = \text{Resin filling volume (L)} \times 100\%$

**Note!**

1、 \*The setting water refers to the process of jet injection quantity sum, including Brine Absorption and slow washing quantity;

2、 \*\*1/5 of the set water amount is the salt tank refill water and 4/5 is the washing water. This ratio is based on the valve body channel design and test. The total water quantity shall be based on 200% resin filling quantity, and the principle shall meet the requirements of  $1/5 \times 200\% = 40\%$  resin filling quantity (1 liter of pure brine regenerate 2.5 liters of resin). . The only way to increase the salt absorption is to increase the value of this parameter;

3、 Water hardness unit is mmol/L;

4、 Resin work exchange capacity calculating is  $1000 \text{ mol/m}^3$ ;

5、 Design and calculation of brine concentration is 20%;

6、 1Liter brine(20%)Molar value= $1000g \times 20\% / 58.8g(\text{NaCl}) \times 1.4(\text{specific consumption}) \approx 200/80 = 2.5\text{mol}$

**VI Mode choice****(1) Meter mode "  " (Default mode)**

Under normal circumstances, should choose meter mode, the mode is not affected by the feed water pressure changes in equipment operation effect. Very important, the flow meter have water stop memory.

**(2) Time mode "  " (standby mode)**

When the water pressure is stable, instantaneous water yield stability,

equipment according to user requirements can choose **Time mode**. If the flow meter is fault, you can switch to **Time mode** by the button  temporary.

### VII. Curve of Flow and Pressure for the Valve

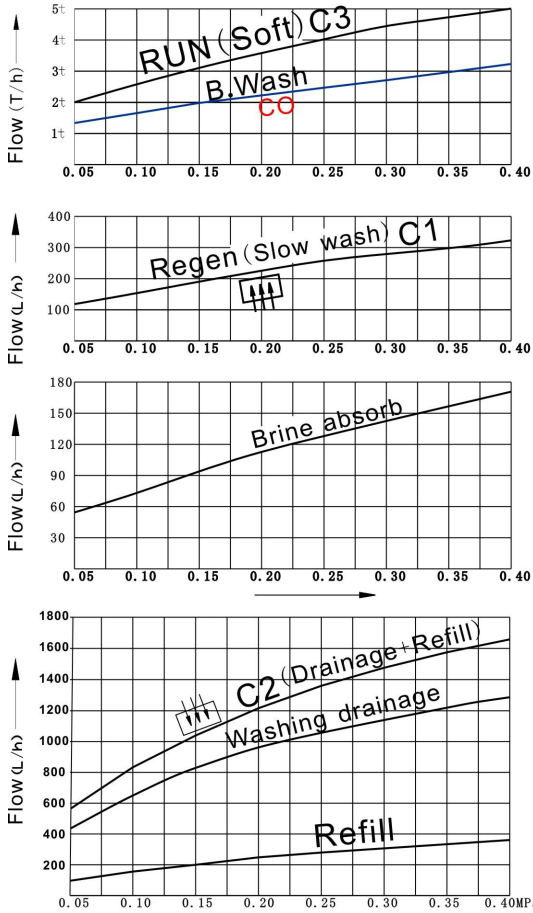

GRDR2-1 Flow pressure curve

Pic14: GR2-1 /DR2-1 Curve of Flow and Pressure for the Valve

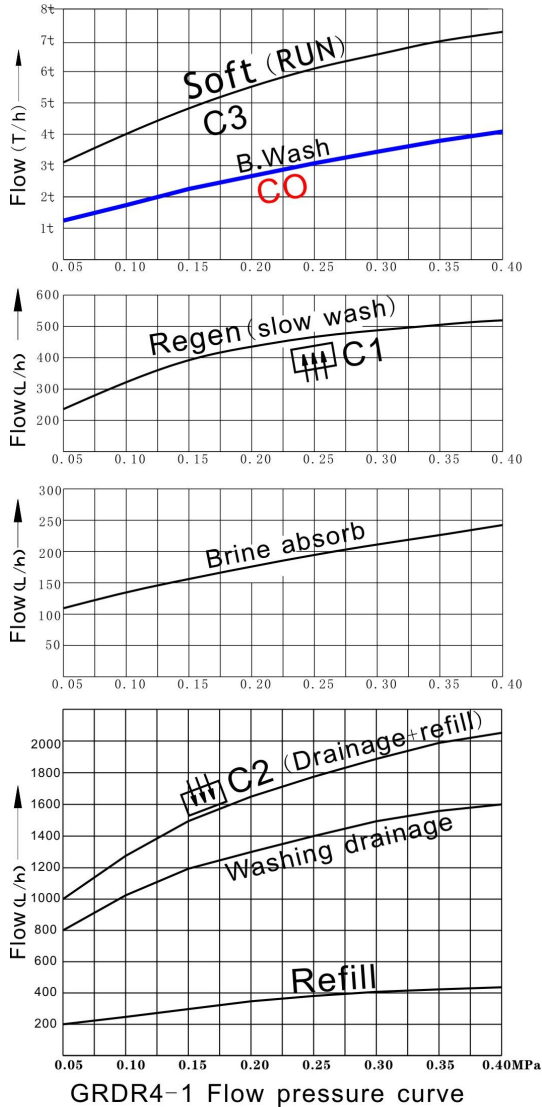

**Pic15: GR4-1 /DR4-1 Curve of Flow and Pressure for the Valve**

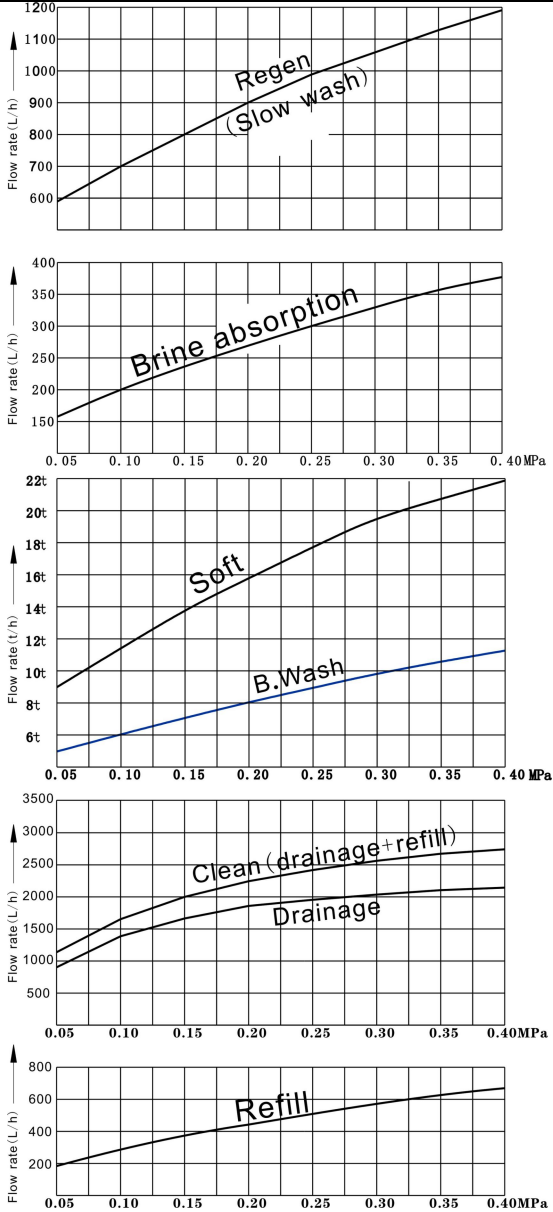

**Pic16: GR10-1\GR10-1S Flow and Pressure curve**

## VIII. Tips and Precautions for Equipment

### Produced water is not qualified

Phenomena/reasons	Solution
No salt in the salt tank	Add salt to the brine tank
No enough absorption of salt water	Increase “  Clean” setting value to increase refilling water to salt tank
DR type No enough resin and too much space at the top of the tank	Add more resin or other to reduce the space
The sealing problem of the center pipe or the pipe is too short	Check the center pipe and the sealing ring



### Brine water leaking out to the water outlet

Phenomena/reasons	Solution
Insufficient amount of cleaning	Increase “  Brine ” value to extended slow wash time

### Increase of the inflow pressure and decrease of the flow rate of outlet

Phenomena/reasons	Solution
Resin is being polluted by the suspended matter	Manual carry out Backwash in unlock state, or reduce the backwash cycle, or increases B.wash water amount
Water distributor is blocked by broken resin	Unload the water distributor and clean it.
Water Outlet pipe system have jam phenomenon	Check and eliminate the problem

**The salt tank overflowed**

Phenomena/reasons	Solutions
The  Clean value setting is too large or the salt tank is too small	Reduce the parameter of the  . or exchange the large salt tank

**No brine absorb in**

Phenomena/reasons	Reasons and Solution
Drainage pipe have less water out, no brine absorption	Check whether the drain pipe system have any jam ,or check the jet nozzle has any jam
Inflow pressure become low	Check feed water and inflow pipe system have any jam.

**IX. Tips and Precautions of Equipment****1. Add salt to salt tank**

The equipment should use large particles industrial salt. If some fine salt is used, please keep it at small amount. Otherwise, it will get agglomerated, leak to the salt filter and clog the tube.

**2. Clean salt tank**

The bottom of the salt tank needs to be checked frequently; the deposit and sludge need to be cleared out.

**3. Clean inflow filter**

The filter of inflow needs to be cleaned periodically in case that the inflow clogs the tubes and leads to low efficiency of the equipment as well as the decrease of the outflow amount.

## X Control valve structure

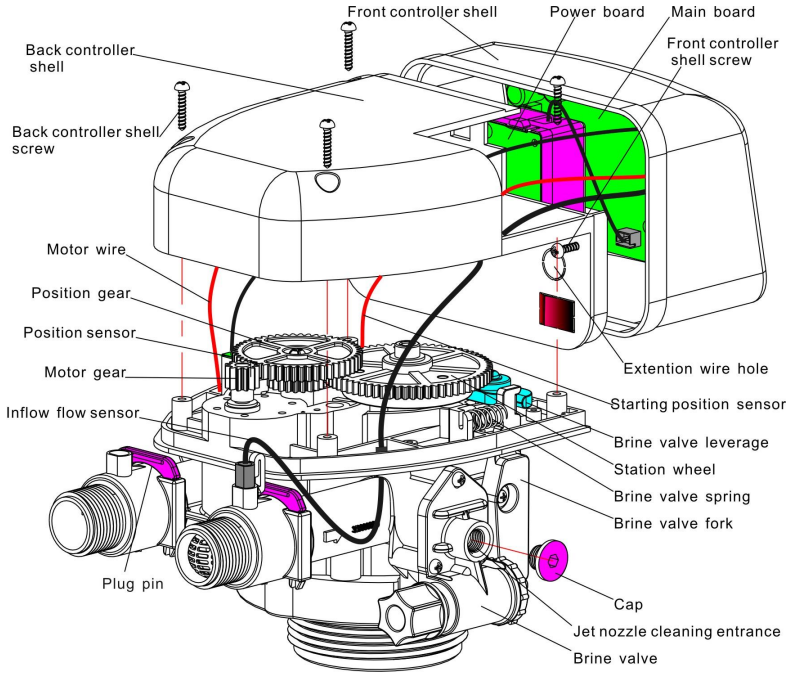

**Pic17: Control valve structure(GRDR2-1\GRDR4-1)**

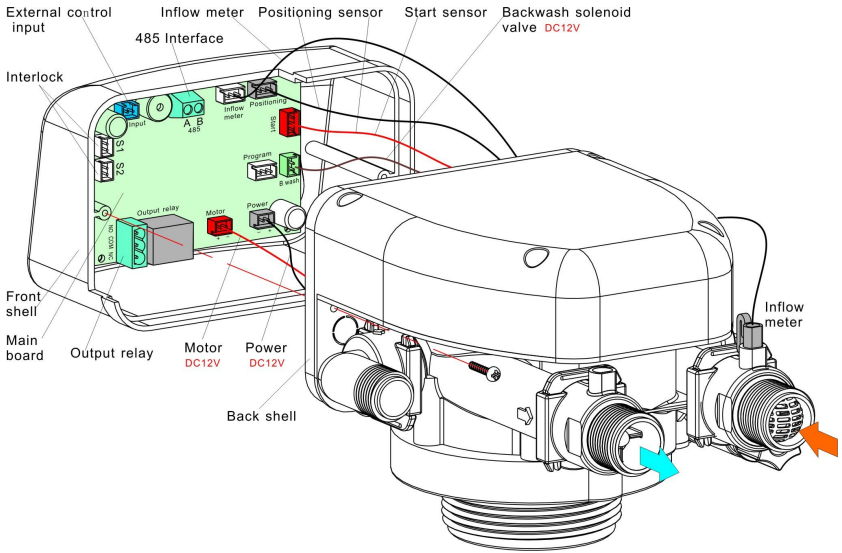

**Pic18: Controller front shell disassembly(GRDR2-1\GRDR4-1)**

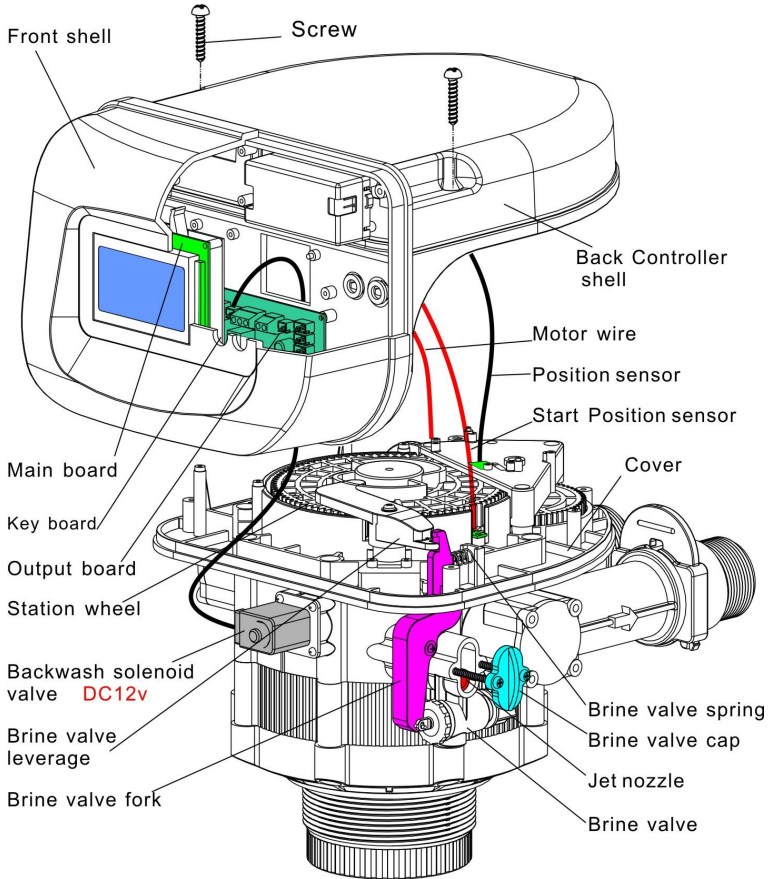

**Pic19: GRDR10-1 Control valve structure**

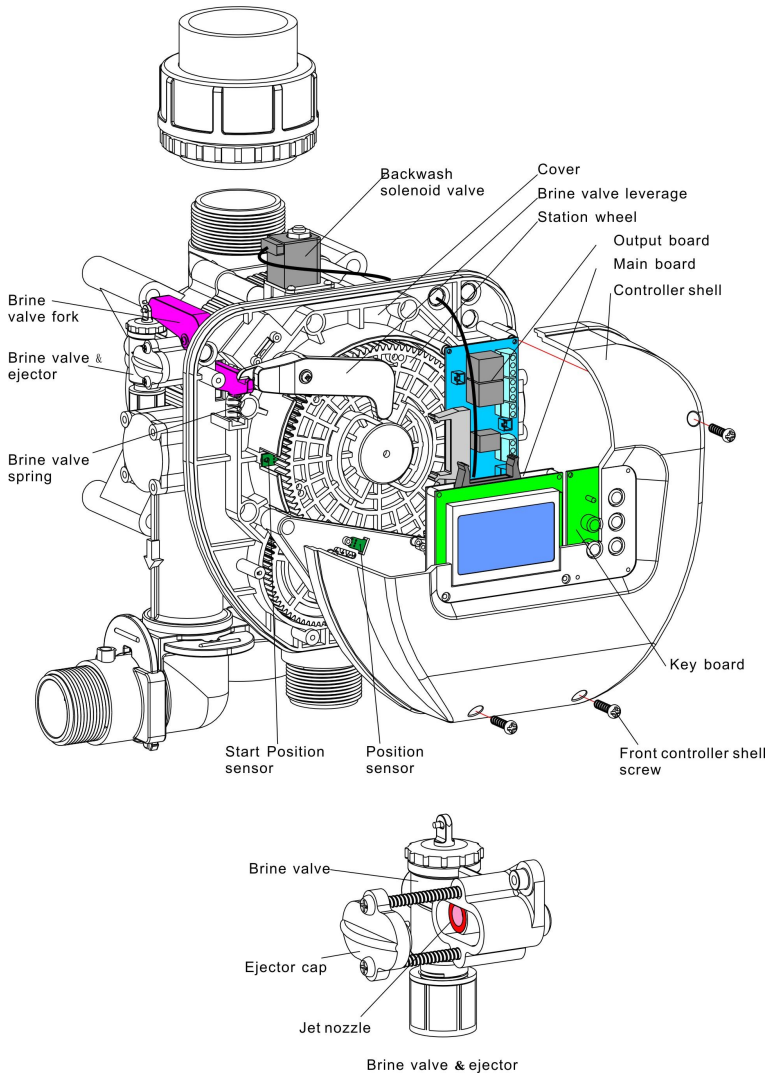

**Pic20: GRDR10-1S Control valve structure**

## XI、Explode drawing (GR4-1 example)

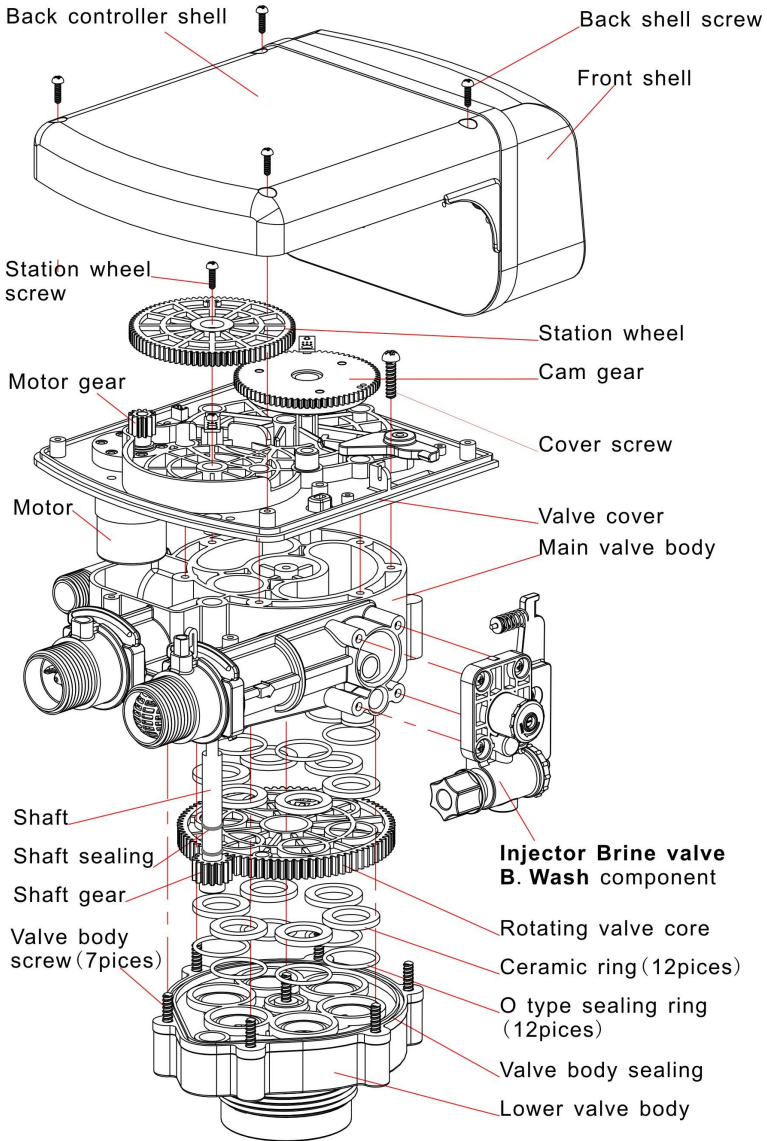

Pic21:Explode drawing (GR4-1 example)

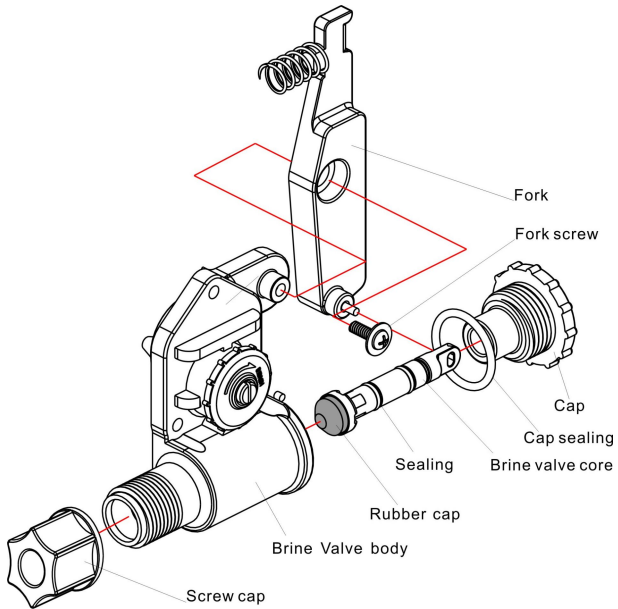

**Pic22:Brine valve explode drawing (GR2-1 example)**